



OWNER'S MANUAL

FOR ALL IRON SLAYER SYSTEMS

THIS MANUAL IS TO BE LEFT WITH THE OWNER OF THE EQUIPMENT FOR REFERENCE AND PURPOSES AND TECHNICAL GUIDANCE. IT IS STRONGLY RECOMMENDED THAT QUALIFIED DEALER SERVICE PERSONNEL BE CONTACTED IN THE EVENT OF AN UNKNOWN INTERRUPTION OF SERVICE OR APPARENT PRODUCT MALFUNCTION. AN ANNUAL PREVENTATIVE MAINTENANCE INSPECTION BY A WATER DEPOT PROFESSIONAL IS RECOMMENDED TO ENSURE TROUBLE-FREE AND CONTINUOUS OPERATION.

www.waterdepot.com

Table of Content

Table of Content	2
Introduction	3
Specifications	3
Instructions.....	4
Installation Fitting Assemblies	5
Bypass Valve Operation.....	5
Consumer Valve Programming Set-up – Econo Iron Slayer	7
Iron Slayer System Setup - Econo	8
Iron Slayer Setting Options	10
Econo Iron Slayer Control Valve Function and Cycles of Operation	12
Iron Slayer System Setup - Econo	13
User Displays – Econo Iron Slayer	15
Troubleshooting Guide – Platinum Iron Slayer	16

Water Depot
92 Commerce Park Drive, Unit 2
Barrie, ON
L4N 8W8

www.waterdepot.com

Introduction

This manual is about a control valve to be used on Backwashable Filters. The manual is designed to aid water treatment equipment manufacturers in the selection of the various control valve options. Information in this manual is different than what is needed for installation and servicing of a particular water treatment system. This manual is not intended to be used as a manual for a complete filter. Certain parts of the manual will serve as aids to manufacturers in the writing and layout of the manuals for installers and service personnel.



Specifications

ECONO SERIES IRON SLAYER – 1500 ELECTRONIC TIMER

PART NUMBER	DESCRIPTION
WD BTC1	1.0 cu. ft. carbon
WD BTC2	2.0 cu. ft. carbon
WD BTMC1	1.0 cu. ft. multimedia and other medias

* ALL LISTED BACKWASHABLE FILTERS INCLUDE VALVE, CONTACT TANK, GRAVEL UNDERBEDDING, 1.05" DISTRIBUTOR, TOP DISTRIBUTOR, BYPASS VALVE, ADAPTOR KIT, SERIES 1500 CONTROL VALVE AND MEDIA

SPECIFICATIONS	BTC1	BTC2	BTMC1
MINERAL TANK SIZE	10" x 44"	12" x 52"	10" x 44"
MEDIA CU. FT	1.0 cu. ft.	2.0 cu. ft.	1.0 cu. ft.
OPERATING PRESSURE	40-100 PSI	40-100 PSI	40-100 PSI
OPERATING TEMPERATURE	40°-120°F	40°-120°F	40°-120°F
PIPE SIZE	1"	1"	1"
SHIPPING WEIGHT	100 lbs	160 lbs	100 lbs
SERVICE FLOW RATE	4 US GPM	5 US GPM	4 US GPM



PLATINUM SERIES IRON SLAYER – 5000 ELECTRONIC TIMER

PART NUMBER	DESCRIPTION
WD BTCP1	1.0 cu. ft. carbon
WD BTCP2	2.0 cu. ft. carbon
WD BTMCP1	1.0 cu. ft. multimedia and other medias

*ALL LISTED BACKWASHABLE FILTERS INCLUDE CHROME SWEAT JACKETS, VALVE, TANK, GRAVEL UNDERBEDDING, 1.05" DISTRIBUTOR, TOP DISTRIBUTOR, BYPASS VALVE, ADAPTOR KIT, SERIES 5000 CONTROL VALVE, BIRM, CARBON, CALCITE, GREENSAND, NEXTSAND MEDIAS

SPECIFICATION	BTCP1	BTCP2	BTMCP1
MINERAL TANK SIZE	10" x 44"	12" x 52"	10" x 44"
MEDIA CU. FT. BIRM	1.0 cu. ft.	2.0 cu. ft.	1.0 cu. ft.
OPERATING PRESSURE	40-100 PSI	40-100 PSI	40-100 PSI
OPERATING TEMPERATURE	40°-120°F	40°-120°F	40°-120°F
PIPE SIZE	1"	1"	1"
SHIPPING WEIGHT	100 lbs	160 lbs	100 lbs
SERVICE FLOW RATE	4 US GPM	6 US GPM	4 US GPM



Instructions

The control valve, fittings and/or bypass are designed to accommodate minor plumbing misalignments but are not designed to support the weight of a system or the plumbing.

Do not use Vaseline, oils, other hydrocarbon lubricants or spray silicone anywhere. A silicon lubricant may be used on black o-rings but is not necessary. **Avoid any type of lubricants, including silicone, or red or clear lip seals.**

The nuts and caps are designed to be unscrewed or tightened by hand or with the special plastic wrench. If necessary, pliers can be used to unscrew the nut or cap. Do not use a pipe wrench to tighten or loosen nuts or caps. Do not place screwdriver in slots on caps and/or tap with a hammer.

Do not use pipe dope or other sealant on threads. Teflon tape must be used on the threads of the 1" NPT elbow or the 1/4" NPT connection and on the threads for the drain line connection. Teflon tape is not necessary on the nut connection or caps because of o-ring seals.

After completing any valve maintenance involving the drive assembly or the drive cap assembly and pistons, press and hold NEXT and REGEN buttons for 3 seconds or unplug power source jack from the printed circuit board (black wire) and plug back in. This resets the electronics and establishes the service piston position. The display should flash all wording, then flash the software version (e.g. 154) and then reset the valve to the service position.

All plumbing should be done in accordance with local plumbing codes. The pipe size for the drain line should be a minimum of 1/2". Backwash flow rates in excess of 7 gpm or length in excess of 20 feet require 3/4" drain line.

Solder joints near the drain must be done prior to connecting the drain line flow control fitting. Leave at least 6" between the drain line control fitting and solder joints when soldering pipes that are connected on the drain line control fitting. Failure to do this could cause interior damage to the drain line flow control fitting.

When assembling the installation-fitting package (inlet and outlet), connect the fitting to the plumbing system first and then attach the nut, split ring and o-ring. Heat from soldering or solvent cements may damage the nut, split ring or o-ring. Solder joints should be cool and solvent cements should be set before installing the nut, split ring and o-ring. Avoid getting primer and solvent cement on any part of the o-rings, split rings, and bypass valve or control valve.

Plug into an electrical outlet. Note: All electrical connections must be connected according to local codes. (Be certain the outlet is uninterrupted.)

Install grounding strap on metal pipes, one end on inlet (copper) and other end to outlet (copper).

Installation Fitting Assemblies

The installation fittings connect to the control valve or the bypass valve using nuts that only require hand tightening. Hand tighten nut connections between control valve and installation fittings, control valve and bypass valve, and bypass valve and installation fittings allow for easy serviceability. Do not use a pipe wrench to tighten nuts on installation fittings. Hand tighten only.

Split ring retainer design holds the nut on and allows load to be spread over the entire nut surface area reducing the chance for leakage. The split ring design, incorporated into the installation fittings allows approximately 2 degrees off axis alignment to the plumbing system. The installation fittings are designed to accommodate minor plumbing misalignments but are not designed to support the weight of a system of the plumbing.

When assembling the installation fitting package, connect the fitting to the plumbing system first and then attach the nut, split ring and o-ring. Heat from soldering or solvent cements may damage the nut, split ring or o-ring. Solder joints should be cool and solvent cements should be set before installing the nut, split ring and o-ring. Avoid getting primer and solvent cement on any part of the o-rings. Split rings, bypass valve or control valve. Solvent cements and primers should be used in accordance with the manufacturer's instructions.

Slip the nut onto the fitting first, then the split ring second and the o-ring last. **HAND TIGHTEN THE NUT.** If the fitting is leaking, tightening the nut will not stop the leak. Remove the nut, remove the fitting, and check for damage or misalignment of the o-ring.

Do not use pipe dope or other sealant on threads. Teflon tape must be used on the threads of the 1" NPT elbow and the ¼" NPT connection and on the threads for the drain line connection. Teflon tape is not necessary on the nut connection or caps because of the o-ring seals.

Bypass Valve **See page 6 for diagram and operation layout**

The bypass valve easily connects to the control valve body using nuts that only require hand tightening. Hand tighten nut connections between control valve and fittings, control valve and bypass valve, and bypass valve and installation fittings allow for easy serviceability. The split ring retainer design holds the nut on and allows load to be spread over the entire nut surface area reducing the chance for leakage. The split ring design, incorporated into the bypass, allows approximately 2 degrees off axis alignment to the plumbing system. The bypass is designed to accommodate minor plumbing misalignments but is not designed to support the weight of a system of the plumbing.

Avoid getting primer and solvent cements on any part of the o-rings or split rings, bypass valve or control valve. Do not use pipe dope or other sealant on threads. Teflon tape is not necessary on the caps because of o-rings seals.

Do not use Vaseline, oils, or other unacceptable lubricants on o-rings. A silicon lubricant may be used on black o-rings. All seals are self-lubricating E.PPM. for long life lubricating qualities.

Note: Quick connect 1" nut will fit around a ¾" copper elbow. (for ease of installation)

BYPASS VALVE OPERATION

Figure 1

NORMAL OPERATION

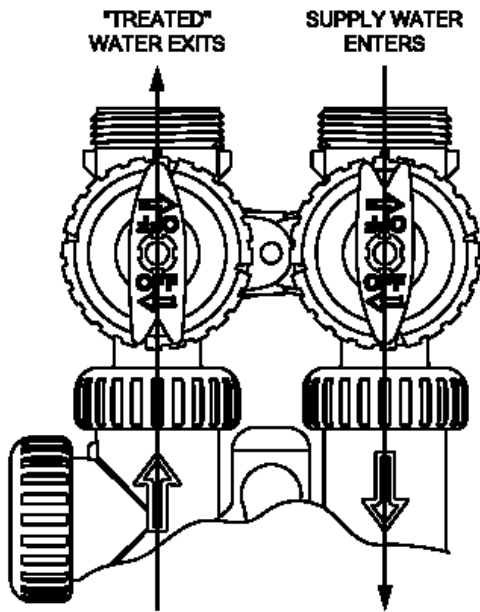

Figure 2

BYPASS OPERATION

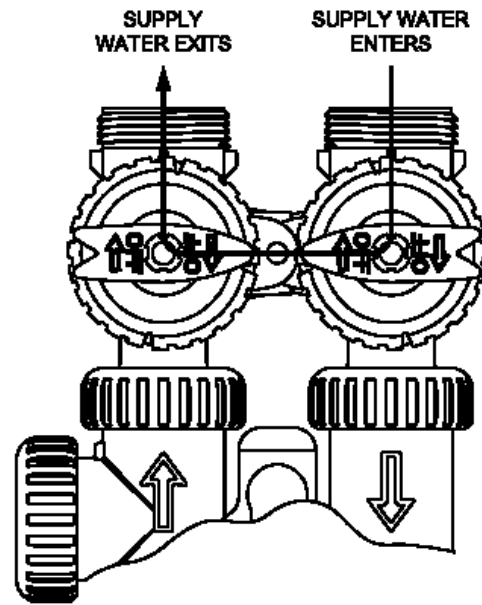

Figure 3

DIAGNOSTIC MODE

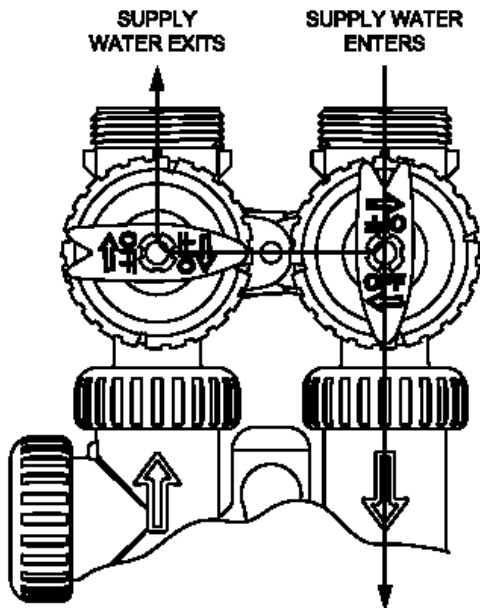
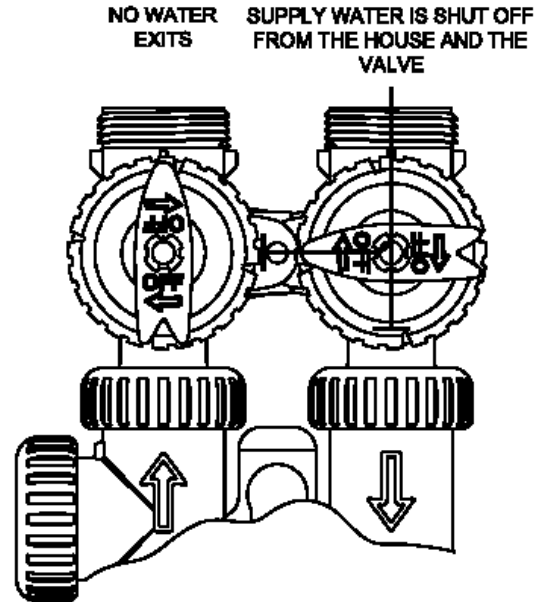

Figure 4

SHUT OFF MODE



Consumer Valve Programming Set-up – Econo Iron Slayer

GENERAL OPERATION

When the system is operating, two displays will be shown: time of day or days until the next regeneration. pressing UP or DOWN will toggle between the two choices.

TO SET TIME OF DAY

In the event of a power outage, time of day needs to be reset. All other information will be stored in memory no matter how long the power outage. Please complete the steps as shown to the right. To access this mode, press SET HOUR.

1. Accessed by pressing SET HOUR.
2. Adjust to the nearest hour using UP or DOWN. An arrow points to PM during p.m. hours.
3. Press SET HOUR to complete and return to normal operation.

TO SET TIME OF REGENERATION

For initial set-up or to make adjustments, please complete the steps as shown to the right. Access the mode by pressing SET HOUR and UP simultaneously for 3 seconds.

1. Accessed by pressing SET HOUR and UP simultaneously for 3 seconds.
2. Adjust time of regeneration hour using the UP or DOWN. An arrow points to PM during p.m. hours. Simultaneously press SET HOUR and DOWN to return to normal operation.

The user can initiate manual regeneration. The user has the option to request the manual regeneration at the delayed regeneration time or to have the regeneration occur immediately. Simultaneously press the UP + DOWN buttons to start regeneration at the next delayed regeneration time. If regeneration is to occur today an arrow will point to regeneration. For immediate regeneration, simultaneously press and hold the UP + DOWN buttons for three seconds.

When in regeneration step through the different regeneration cycles by simultaneously pressing the UP + DOWN buttons.

User Please Note: Please Do not attempt to go further into valve programming other than time of day or regeneration unless you have a full and comprehensive understanding of all program features. Incorrect settings may result in a labor service charge.

Iron Slayer System Setup - Econo

In Filter System Setup choose the time for the cycles selected in Cycle Sequence and specifies other operating parameters for the system. The upper and lower limits of the allowable values for the cycles are as follows:

Cycle Options	Units	Lower/Upper Limit	Default
Backwash	Minutes	1 to 120	8
Rinse (fast)	Minutes	1 to 120	4
dn Brine (combination of regenerant and slow rinse)	Minutes	1 to 180	60
UP Brine (combination of regenerant and slow rinse)	Minutes	1 to 180	60
Fill	Minutes	0.01 to 20.00	0.95
Service	Minutes	1 to 480	240

NOTE: Fill is in gallons.

ciated with the END cycle, the END cycle will not appear in the Filter System Setup sequence.

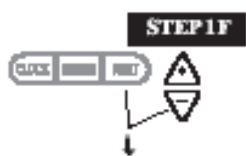

Step 1F – Press NEXT and ▲ simultaneously for 3 seconds and release. If screen in Step 2F does not appear in 5 seconds the lock on the valve is activated. To unlock press ▲, NEXT, ▼, and CLOCK in sequence, then press NEXT and ▼ simultaneously for 3 seconds and release.

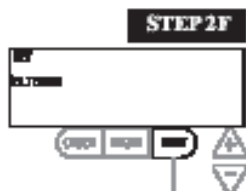

Step 2F – Choose FILTERING using the ▼ or ▲ buttons. Press NEXT to go to Step 3F. Press REGEN to exit Filter System Setup.



Step 3F – Select the time for the first cycle (which in this example is BACKWASH) using the ▲ or ▼ button. Press NEXT to go to Step 4F. Press REGEN to return to previous step.



Step 4F – Select the time for the second cycle (which in this example is dn BRINE) using the ▼ or ▲ button. Press NEXT to go to Step 5F. Press REGEN to return to previous step. NOTE: The display will flash between cycle number and time, and brine direction (dn or UP).



Step 5F – Select the time for the third cycle (which in this example is RINSE) using the ▲ or ▼ button. Press NEXT to go to Step 6F. Press REGEN to return to previous step.



Step 6F – Select the gallons for the fourth cycle (which in this example is FILL) using the ▲ or ▼ button. Press NEXT to go to Step 7F. Press REGEN to return to previous step.



Step 7F – Set Volume Capacity using the ▼ or ▲ button. If value is set to:

- “oFF” regeneration will be based solely on the day override set (see Installer Display/Settings Step 3I); or
- as a number (allowable range 20 to 250,000) regeneration initiation will be based off the value specified. Increment increase is 20 for the range 20 to 2,000, 100 for the range of 2,000 to 10,000, 500 for the range 10,000 to 50,000 and 2,000 for the range of 50,000 to 250,000. See Table 9 for more detail. Press NEXT to go to Step 8F. Press REGEN to return to previous step.



Step 8F – Set Regeneration Time Options using the ▼ or ▲ button. If value is set to:

- “NORMAL” means regeneration will occur at the preset time;
- “on 0” means regeneration will occur immediately when the gallons capacity reaches 0 (zero); or
- “NORMAL + on 0” means regeneration will occur at one of the following:
 - the preset time when the gallons capacity falls below the reserve or the specified number of days between regenerations is reached whichever comes first; or
 - after 10 minutes of no water usage when the gallon capacity reaches 0 (zero).

See Table 9 for more detail. Press NEXT to go to Step 9F. Press REGEN to return to previous step.

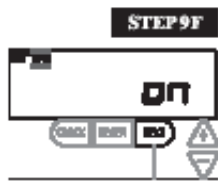

Displays 9F, 10F and 11F are unique to the V3353HR WS1HR PC Board w/Relay. See WS1HR&HS & WS1.25HR&HS Front Cover and Drive Assembly diagram. If using a CLK V3353HS WS1HS PC Board proceed to Step 12F.

Step 9F: Set Relay operation using the ▼ or ▲ button. The choices are:

- Set Time on: Relay activates after a set time at the beginning of a regeneration and then deactivates after a set period of time. The start of regeneration is defined as the .rst backwash cycle, Dn brine cycle or UP brine cycle which ever comes .rst.
- Set Gal on: Relay activates after a set number of gallons has been treated and then deactivates after a set period of time or after the meter stops registering .ow, whichever comes .rst.
- Off: If set to Off, Steps 10F and 11F will not be shown.

Press NEXT to go to Step 10F. Press REGEN to return to previous step.



Step 10F: Set Relay Actuation Time or Gallons using the ▼ or ▲ buttons. The choices are:

- Relay Actuation Time: After the start of a regeneration the amount of time that should pass prior to activating the relay. The start of regeneration is defined as the .rst backwash cycle, Dn brine cycle or UP brine cycle which ever comes .rst. Ranges from 1 second to 200 minutes.
- Relay Actuation Gallons: Relay activates after a set number of gallons has passed through the meter when the valve is in the Service mode. Ranges from 1 to 50 gallons.

Press NEXT to go to Step 11F. Press REGEN to return to previous step.

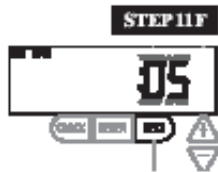

Step 11F: Set Relay Deactivate Time using the ▲ or ▼ buttons.

- If Set Time on is selected in Step 9F the relay will deactivate after the time set has expired. Ranges from 1 second to 200 minutes.
- If Set Gal on is selected in Step 9F the relay will deactivate after the time set has expired or after the meter stops registering .ow, whichever comes .rst. Ranges from 1 second to 20 minutes.

Press NEXT to go to Step 12F. Press REGEN to return to previous step.

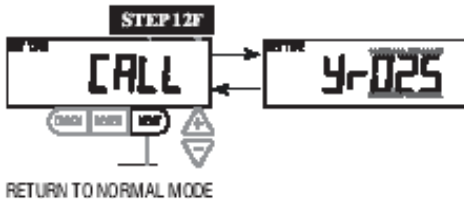

Step 12F: Set the Service Call Indicator by using the ▼ or ▲ buttons. Range is in ¼ of a year increments from 0.25 to 9.75 years. Selecting OFF will disable this feature. Press NEXT to exit Filter System Setup. Press REGEN to return to previous step.

Iron Slayer Setting Options

Gallons Capacity	Regeneration Time Option	Day Override	Result
OFF	NORMAL	Any number	Reserve capacity not automatically estimated. Regeneration occurs at the next Regen Set Time when the specified number of days between regenerations is reached.
Any number	NORMAL	OFF	Reserve capacity not automatically estimated. Regeneration occurs at the next Regen Set Time when gallons capacity reaches 0.
Any number	NORMAL	Any number	Reserve capacity not automatically estimated. Regeneration occurs at the next Regen Set Time when gallons capacity reaches 0 or the specified number of days between regenerations is reached.
Any number	On 0	OFF	Reserve capacity not automatically estimated. Regeneration occurs immediately when gallons capacity reaches 0. Time of regeneration will not be allowed to be set because regeneration will always occur on 0.
Any number	NORMAL on 0	Any number	Reserve capacity not automatically estimated. Regeneration occurs at the next Regen Set Time when the specified number of days between regenerations is reached or regeneration occurs immediately after 10 minutes of no water usage when gallon capacity reaches 0.

User Display Settings

General Operation

When the system is operating, one of five displays may be shown. The displays normally rotate, however pressing NEXT will pause on the selected display for 5 minutes. Pressing NEXT will alternate between the displays. One of the displays is always the current time of day. The second display is one of the following: days remaining or volume remaining. Days remaining is the number of days left before the system goes through a regeneration cycle. Capacity remaining is the gallons that will be treated before the system goes through a regeneration cycle. Pressing the ∇ button while in the Capacity Remaining display will decrease the capacity remaining in 10 gallon increments and will also increase the volume used impacting the recorded values in Diagnostics Steps 3D, 4D and 5D and Valve History, Step 4VH. The third display shows the current treated water flow rate through the system. The fourth display will show either dP or hold if the dP switch is closed. The fifth display indicates the user should call for service. The fifth display will not appear if OFF is selected in Step 13S of Softener System Setup or Step 12F of Filter System Setup. To clear the Service Call reminder, press the \blacktriangle and \blacktriangledown buttons simultaneously while CALL is displayed.

If the system has called for a regeneration that will occur at the preset time of regeneration, the words REGEN TODAY will appear on the display.

If a water meter is installed, the word "Softening" or "Filtering" flashes on the display when water is being treated (i.e. water is flowing through the system).

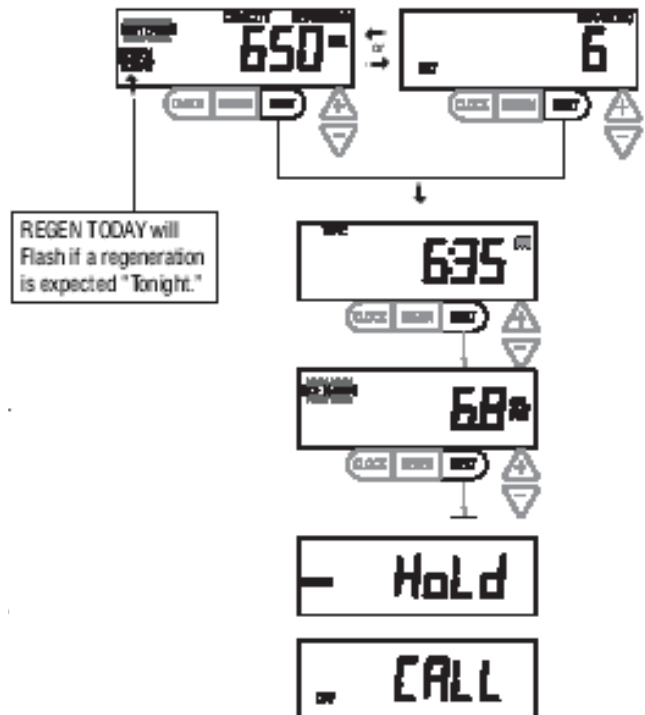

Regeneration Mode

Typically a system is set to regenerate at a time of low water usage. An example of a time with low water usage is when a household is asleep. If there is a demand for water when the system is regenerating, untreated water will be used.



When the system begins to regenerate, the display will change to include information about the step of the regeneration process and the time remaining for that step to be completed. The system runs through the steps automatically and will reset itself to provide treated water when the regeneration has been completed.

Manual Regeneration

Sometimes there is a need to regenerate the system sooner than when the system calls for it, usually referred to as manual regeneration. There may be a period of heavy water usage because of guests or a heavy laundry



To initiate a manual regeneration at the preset delayed regeneration time, when the regeneration time option is set to "NORMAL" or "NORMAL + on 0", press and release "REGEN". The words "REGEN TODAY" will flash on the display to indicate that the system will regenerate at the preset delayed regeneration time. If you pressed the "REGEN" button in error, pressing the button again will cancel the request. Note: If the regeneration time option is set to "on 0" there is no set delayed regeneration time so "REGEN TODAY" will not activate if "REGEN" button is pressed.

To initiate a manual regeneration immediately, press and hold the "REGEN" button for three seconds. The system will begin to regenerate immediately. The request cannot be cancelled.

Note: For softeners, if the brine tank does not contain salt, fill with salt and wait at least two hours before regenerating.

Set Time of Day

The user can also set the time of day. Time of day should only need to be set after extended power outages or when daylight saving time begins or ends. If an extended power outage occurs, the time of day will flash on and off which indicates the time of day should be reset.

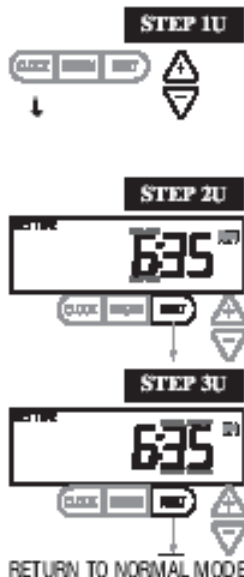

STEP 1U – Press CLOCK.

STEP 2U - Current Time (hour): Set the hour of the day using ▼ or ▲ buttons. AM/PM toggles after 12. Press NEXT to go to Step 3U.

STEP 3U - Current Time (minutes): Set the minutes of the day using ▲ or ▼ buttons. Press NEXT to exit Set Time of Day. Press REGEN to return to previous step.

Power Loss

If the power goes out for less than two hours, the system will automatically reset itself. If an extended power outage occurs, the time of day will flash on and off which indicates the time of day should be reset. The system will remember the rest.

Error Message

If the word "ERROR" and a number are alternately flashing on the display contact the for help. This indicates that the valve was not able to function properly.

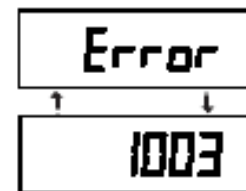

Econo Iron Slayer Control Valve Function and Cycles of Operation

This glass filled Noryl fully automatic control valve is designed as the primary control center to direct and regulate all cycles of a water softener or filter.

The time clock control valve can be set to perform downflow regeneration or simply backwash. The time clock control valve has two calendar options for regeneration frequency:

1. an option where the user can choose the number of days (1-99) between each regeneration, and
2. a seven-day option where the user can choose which day(s) of the week a regeneration should occur.

The control valve is compatible with a variety of regenerants and resin cleaners. The control valve is capable of routing the flow of water in the necessary paths to regenerate or backwash water treatment systems. The injector regulates the flow of brine or other regenerants. The control valve regulates the flow rates for backwashing, rinsing and the replenishing of treated water into a regenerant tank, when applicable.

The control valve is designed to deliver high service (27gpm @ 15 psig) and backwash (27gpm @25psig) flow rates when the by pass has straight fittings. The control valve uses no traditional fasteners (e.g. screws), instead clips, threaded caps and nuts and snap type latches are used. Caps and nuts only need to be firmly hand tightened because radial seals are used. Tools required to service the valve include one small blade screw driver, one large blade screw driver, pliers and a pair of hands. A plastic wrench is available which eliminates the need for screwdrivers and pliers. Disassembly for servicing takes much less time than comparable products currently on the market. Control valve installation is made easy because the distributor tube can be cut ½ " above to ½ " below the top of tank thread. The distributor tube is held in place by an o-ring seal and the control valve has a bayonet lock feature for upper distributor baskets.

The transformer power pack comes with a 15 foot power cord and is designed for use with the control valve. The transformer power pack is for dry location use only. If the power goes out, only the time of day needs to reset. All other values are permanently stored in the nonvolatile memory.

Table 3 shows the time for the backwash, regenerative, and rinse cycles for the ten available programming options. Six different programs are available for a softener, one for a regenerative filter, and three programs for backwash only filters. When the control valve is used as a:

1. softener, one or two backwashes occur and refill always occurs after the rinse cycle (P0 through P5);
2. regenerative filter, one backwash occurs and refill always occurs after the rinse cycle (P6); and
3. backwashing filter, one backwash occurs (P7 through P9).

Regeneration Cycles and Times for Different Programs

Program	All Times in Minutes				
	C1 1 st Backwash	C2 Regenerate	C3 2 nd Backwash	C4 Rinse	C5 Fill
P0	3	50	3	3	1-99
P1	8	50	8	4	1-99
P2	8	70	10	6	1-99
P3	12	70	12	8	1-99
P4	10	50	Skipped	8	1-99
P5	4	50	Skipped	4	1-99
P6	12	6	Skipped	12	1-99
P7	6	Skipped	Skipped	4	Skipped
P8	10	Skipped	Skipped	6	Skipped
P9	14	Skipped	Skipped	8	Skipped

Note: During regeneration the display will show C1, C2, etc. etc. If the cycle is skipped, that Cycle number will not be displayed.

Please Note:

8" Should use preset P9 and 10" units should use preset P9

Iron Slayer System Setup - Econo

Installers Displays & Settings (1-99 Days Between Regeneration option)

STEP 11D



STEP 11D – From normal mode, press SET HOUR + UP buttons simultaneously for 3 seconds and release.

STEP 21D

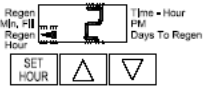

STEP 21D – Regeneration Time: Set the clock to the hour the regeneration should occur by using the UP or DOWN buttons. An arrow points to PM after 12. Press SET HOUR to go to STEP 31D.

STEP 31D



STEP 31D – Days to Regen: Set the number of days between regenerations. The allowable range is 1 to 99. Press SET HOUR to exit Installer Displays & Settings.

Return to Normal Mode

STEP 117

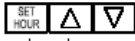

STEP 117 – From normal mode, press SET HOUR + UP buttons simultaneously for 3 seconds and release.

STEP 217

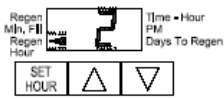

STEP 217 – Regeneration Time: Set the clock to the hour the regeneration should occur by using the UP or Down buttons. An arrow points to PM after 12. Press SET HOUR to go to STEP 317.

STEP 317

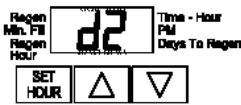

STEP 317 – Current Day of the week: Set the current day of the week by using the UP or DOWN buttons (see chart at right for date codes). Press SET HOUR to go to STEP 417

STEP 417

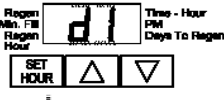

STEP 417 – Sunday Regeneration: To regenerate on Sunday use the UP or DOWN Button until the arrow points to Regen. If the arrow does not point to Regen a Regeneration will not occur on Sunday. Press SET HOUR to go to STEP 517.

STEP 517



STEP 517 – Monday Regeneration: To regenerate on Monday use the UP or DOWN button until the arrow points to Regen. If the arrow does not point to Regen a regeneration will not occur on Monday. Press SET HOUR to go to STEP 617.

STEP 617

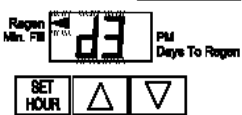

STEP 617 – Tuesday Regeneration: To regenerate on Tuesday use the UP or DOWN button until the arrow points to Regen. If the arrow does not point to Regen a regeneration will not occur on Tuesday. Press SET HOUR to go to STEP 717.

STEP 717



STEP 717 – Wednesday Regeneration: To regenerate on Wednesday use the UP or DOWN button until the arrow points to Regen. If the arrow does not point to Regen a Regeneration will not occur on Wednesday. Press SET HOUR to go to STEP 817.

Installer Displays & Settings (7 day option)

Display	Day of Week
d1	Sunday
d2	Monday
d3	Tuesday
d4	Wednesday
d5	Thursday
d6	Friday
d7	Saturday

STEP 817

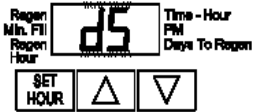

STEP 817 – Thursday Regeneration: To regenerate on Thursday use the UP or DOWN Button until the arrow points to Regen. If the arrow does not point to Regen a regeneration will not occur on Thursday. Press SET HOUR to go to STEP 917.

STEP 917



STEP 917 – Friday Regeneration: To regenerate on Friday use the UP or DOWN button until the arrow points to Regen. If the arrow does not point to Regen a regeneration will not occur on Friday. Press SET HOUR to go to STEP 1017.

STEP 1017

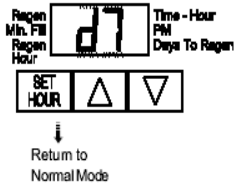

STEP 1017 – Saturday Regeneration: To regenerate on Saturday use the UP or DOWN button until the arrow points to Regen. If the arrow does not point to Regen a regeneration will not occur on Saturday. Press SET HOUR to exit Installer Displays Settings.

NOTE: if all arrows are turned off in d1-d7, Days to Regen in the User Displays will always read 7 and a regeneration will never occur.

User Displays – Econo Iron Slayer

General Operation

When the system is operating one of two displays will be shown. Pressing UP or DOWN button will alternate between the displays. One of the displays is always the current time of day (to the nearest hour). The second display is the days remaining until next regeneration. If the days remaining is equal to one, a regeneration will occur at the next preset regeneration time. The user can scroll between displays as desired.

If the system has called for a regeneration that will occur at the present time of regeneration, the arrow will point to Regen.

Regeneration Mode

Typically a system is set to regenerate at a time of low water usage. An example of a time with low water usage is when a household is asleep. If there is a demand for water when the system is regenerating, untreated water will be used.

When the system begins to regenerate, the display will change to indicate the cycle of the regeneration process (see Table 3) that is occurring and an arrow will also point to Regen. The system will run through the steps automatically and will reset itself provide treated water when the regeneration is completed.

Manual Regeneration

Sometimes there is need to regenerate the system, sooner than when the system calls for it, usually referred to as a manual regeneration. There may be a period of heavy water usage because of guests or a heavy laundry day.

To initiate a manual regeneration at the preset delayed regeneration time, simultaneously press UP-DOWN buttons together and release. The arrow will point to the word Regen if a regeneration is expected "tonight". To cancel the regeneration simultaneously press UP + DOWN buttons and release.

To initiate a manual regeneration immediately, simultaneously press UP + DOWN buttons together for three seconds. The system will begin to regenerate immediately. The request cannot be cancelled. Note: For softeners, if brine tank does not contain salt, fill with salt and wait at least two hours before regenerating.

Set Time of Day

STEP 1U – Press SET HOUR

STEP 2U – Current: Set the clock to the closest hour by using the UP and DOWN button. An arrow points to PM after 12. After a power outage, the time of day will need to be reset. Press SET HOUR to exit.

Power Loss

If the power goes out current timer of day will need to be reset. If the power goes out while the system is regenerating, the cycle picks up where it was interrupted when the power returns. Note: The display will flash if a power outage has occurred.

Error Message

If "E1," "E2" or "E3" appears on the display contact the help. This indicates that the valve did not function properly.

Troubleshooting Guide – Platinum Iron Slayer

Problem	Possible Cause	Solution
1. Timer does not display time of day	a. Transformer unplugged	a. Connect power
	b. No electric power at outlet	b. Repair outlet or use working outlet
	c. Defective transformer	c. Replace transformer
	d. Defective PC board	d. Replace PC board
2. Timer does not display correct time of day	a. Switched outlet	a. Use uninterrupted outlet
	b. Power outage	b. Reset time of day
	c. Defective PC Board	c. Replace PC board
3. Control valve regenerates at wrong time of day	a. Power outages	a. Reset control valve to correct time of day
	b. Time of day not set correctly	b. Reset to correct time of day
	c. Time of regeneration incorrect	c. Reset regeneration time
4. E1, E2 or E3 E1-Unable to recognize start of regeneration E2-Unexpected stall E3-Motor ran to long, timed out trying to reach the next cycle position or trying to reach home position	a. Control valve has just been serviced	a. Press SET HOUR and DOWN for 3 seconds or unplug power source jack (black wire) from the circuit board and plug back in to reset control valve
	b. Foreign matter is lodged in control valve	b. Check piston and spacer stack assembly for foreign matter
	c. High drive forces on piston	c. Replace piston(s) and spacer stack assembly
	d. Control valve piston not in home position	d. Press SET HOUR and DOWN for 3 seconds or unplug power source jack (black wire) from the circuit board and plug back into reset control valve
	e. Motor not inserted fully to engage pinion, motor wires broken or disconnected, motor failure	e. Check motor and wiring. Replace motor if necessary
	f. Drive gear label dirty or damaged, missing or broken gear	f. Replace or clean drive gear
	g. Drive bracket incorrectly aligned to back plate	g. Reset drive bracket properly
	h. PC board is damaged or defective	h. Replace PC board
	i. PC board incorrectly aligned to drive bracket	i. Ensure PC board is correctly snapped on to drive bracket
5. Control Valve stalled in regeneration	a. Motor not operating	a. Replace motor
	b. No electric power at outlet	b. Repair outlet or use working outlet
	c. Defective transformer	c. Replace transformer
	d. Defective PC board	d. Replace PC board
	e. Broken drive gear or drive cap assembly	e. Replace drive gear or drive cap assembly
	f. Broken piston retainer	f. Replace drive cap assembly
	g. Broken main or regenerant piston	g. Replace main or regenerant piston
6. Control valve does not regenerate	a. Transformer unplugged	a. Connect transformer
	b. No electric power at outlet	b. Repair outlet or use working outlet

automatically when UP and DOWN buttons are depressed and held	c. Broken drive gear or drive cap assembly	c. Replace drive gear or drive cap assembly
	d. Defective PC board	d. Replace PC board
7. Control valve does not regenerate automatically but does when UP and DOWN buttons are depressed	a. Defective PC board	a. Replace PC board
	b. Set-up error	b. Check control valve set-up procedure
8. Smell and/or Iron bleeding thru		a. Size of equipment correct
		b. Check media
9. Smell Hot side only		a. Chlorinate hot tank
		b. Optional to remove anode rod.
		c. If condition persists check for sulphur reducing bacteria
10. Black or Grey water (cold side)		a. Unit backwashed thoroughly at install. (backwash now)
		b. Check backwash control
		c. Plugged backwash control
		d. Kinked drain line
12. Excessive noise during backwash		a. Fasten all lines
13. Particles in water (Media-Black)		a. Broken distributor or riser tube.